

R9300P Remote Particle Counters

1.2 LPM

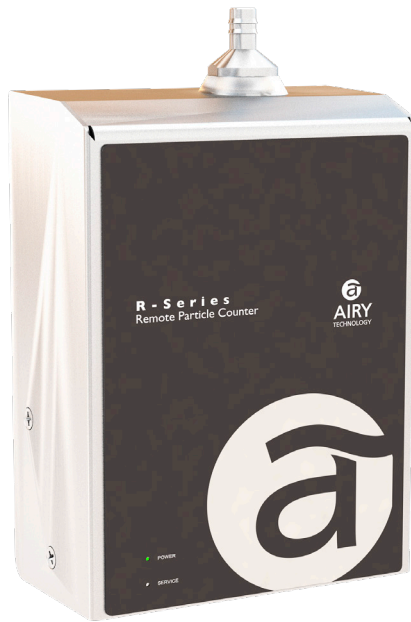

The Airy Technology® R9300P Remote Airborne Particle Counters are designed for continuous monitoring in cleanrooms and other controlled environments. With 30 user-selectable particle size channels ranging from 0.3 up to 25.0 μm and a quiet 1.2 LPM internal pump, these instruments deliver targeted contamination detection with real-time data collection and configurable alarms for immediate incident reporting and local visual alerts.

Calibrated to ISO 21501-4 standards for traceability, the R9300P features onboard storage for redundant data validation and secure user access. The compact, angled enclosure enables installation in tight locations while minimizing disruption to unidirectional airflow.

Built for scalability and long-term reliability, these models utilize durable laser diodes backed by a lifetime warranty, and they deliver exceptional zero-count performance. With seamless connectivity, remote diagnostics, and a standardized architecture, the Airy Technology® R9300P offers simplified integration and a lower total cost of ownership for critical monitoring applications.

Features and Benefits

- 1.2 LPM internal pump flow rate
- Long life laser diode technology for reliable performance
- Measures up to 30 user-selectable particle size channels
- Accurate in high concentration environments with minimal time to zero-count
- Internal vacuum pump and HEPA filtered exhaust
- Troubleshoot issues remotely from anywhere with an internet connection
- Stores up to 65,000 sample records for on-board data redundancy
- Optional temperature and relative humidity probe available
- Connect via Modbus RTU/ASCII over isolated RS-485, TCP/IP, PoE, or WiFi
- Complies with ISO 21501-4 and JIS B9921 standards
- Easy to clean, lightweight stainless steel enclosure with minimal particle traps
- Versatile mounting options
- Alarm light and LED indicators for real-time alerts
- Seamless integration into a facility monitoring system
- 2 Year Limited Warranty (Extended and Lifetime Warranties available)

Specifications

Model	R9300P
Size Range	0.3 μm to 25 μm
Size Channels	Factory calibrated at 0.3, 0.5, 1.0, 2.5, 5.0, 10.0 μm
Counting Efficiency	50% @ 0.3 μm ; 100% for particles > 0.45 μm per JIS
Flow Rate	1.2 LPM
Concentration Limits	27,000,000 particles/ft ³ @ 10% coincidence (per ISO 21501-4), 50,000,000 particles/ft ³ @ 10% coincidence (as tested and validated ¹)
Light Source	Long life laser diode
Zero Count	< 1 count / 60 minutes (< 1 particles / 6ft ³). No fault count subtraction.
Alarms	Channel alarms on Raw counts, concentrations or mass (alarms on environmental sensors optional)
Calibration	NIST traceable
Vacuum Source	Internal vacuum pump with HEPA filter
Filtered Exhaust	Internal HEPA filter
Airflow	Internally monitored
Number of Channels	6 channels (up to 30 channels of simultaneous data)
Configuration/Download	USB mini-B
Alarm	Alarm LED ring
Communication Modes	MODBUS™ RTU or ASCII outputs (over isolated RS-485), TCP/IP, PoE, or WiFi
Optional Environmental Sensor	Temperature and Relative Humidity probe 32° to 122°F (0° to 50°C) \pm 1°F (0.5°C), 15-90% \pm 2% RH
Standards	ISO 21501-4 and JIS B9921
Instrument Calibration	Recommended minimum once per year
External Surface	Stainless steel
Dimensions (L x W x H)	3.5" x 1.8" x 5.6" (8.9 cm x 4.6 cm x 14.2 cm) including probes and connectors
Weight	1.71 lb. (780 grams)
Accessories	Operating manual on USB flash drive, isokinetic probe, power supply and cable
Optional Accessories	Printed manual, barb fittings, mounting bracket, sample tubing, zero-count filter, and temp./RH probe
Buffer Memory	65,000 sample records (rotating buffer) including particle count data and environmental data
Sample Time	1 second to 99 hours
Power	7 - 15 VDC (< 2 watts)
Operating Conditions	41° to 104°F (5° to 40°C) / 20% to 95% non-condensing
Storage Conditions	32° to 122°F (0° to 50°C) / Up to 98% non-condensing
Warranty	2 Year Limited Warranty (Extended and Lifetime Warranties available)

1- Validated by independent analysis see paper available at www.particlesplus.com/aac2022_paper

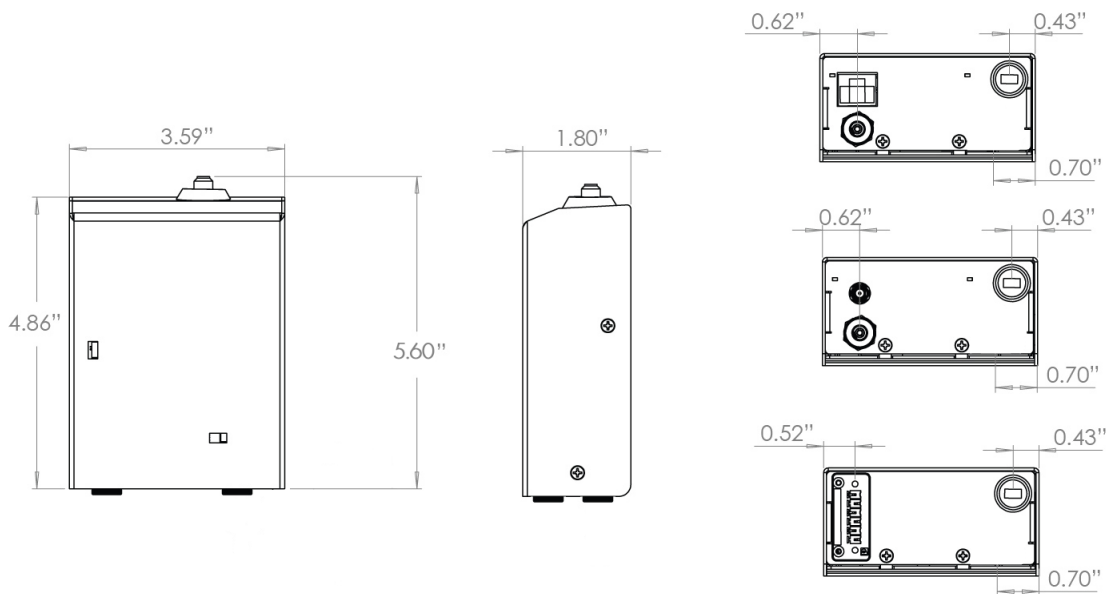

Airy Technology, Inc. reserves the right to change specifications without notice. Contact www.airytechnology.com or your local distributor for more details. Airy Technology and the Airy Technology logo are trademarks of Airy Technology, Inc. ©2025 Airy Technology, Inc. All rights reserved.

REV 20260227-R9300P



1490 Central Street
Stoughton, MA 02072 U.S.A.
+1-781-341-6898
www.airytechnology.com