

# 11000 Ambient Air Monitor

## 1.2 LPM



The Airy Technology® 11000 Ambient Air Quality Monitor is engineered for high resolution, real-time measurement of ambient particulate matter in outdoor environments. Housed in a NEMA 4 weatherproof enclosure, the 11000 series measures particle sizes from 0.3 to 25.0  $\mu\text{m}$  across 30 discrete size channels at a flow rate of 1.2 LPM. Designed for demanding outdoor applications such as roadside monitoring, urban air studies, industrial fence-line monitoring, and environmental research, the 11000 combines rugged durability with industry-leading sensitivity and resolution.

As the first real-time optical particle counter to offer 30 accurate size channels at higher concentrations, the 11000 records size-specific particle data into a 65,000-record non-volatile memory that is critical for applications requiring research-grade particle sizing.

Data can be simultaneously communicated to a remote monitoring system, logged locally, exported as .CSV, and analyzed via the free Airy Technology® software. The system includes remote diagnostics and multiple communication protocols for seamless integration into smart city infrastructure, environmental monitoring networks, and public health initiatives. Whether deployed as a standalone unit or as part of a distributed sensor array, the 11000 delivers best-in-class performance for ultrafine and coarse particle monitoring.

### Features and Benefits

- Measures up to 30 particle size channels simultaneously
- Approximates mass concentration in  $\mu\text{g}/\text{m}^3$  with density and refractive index corrections
- User selectable PM sizes from 0.3  $\mu\text{m}$  to 10  $\mu\text{m}$  including TPM of up to 25.0  $\mu\text{m}$
- Long-life laser diode technology for reliable performance
- Inlet sample humidity and enclosure temperature regulation for precise particle sizing
- Stores up to 65,000 sample records, 1,000 locations, and 50 sampling recipes
- Resolve issues quickly from any location with internet-enabled remote diagnostics
- ULTRAGUARD® Fiberglass reinforced polyester NEMA 4 tamper-proof enclosure
- Optional pole or tripod mount options
- 2 Year Limited Warranty (Extended and Lifetime Warranties available)

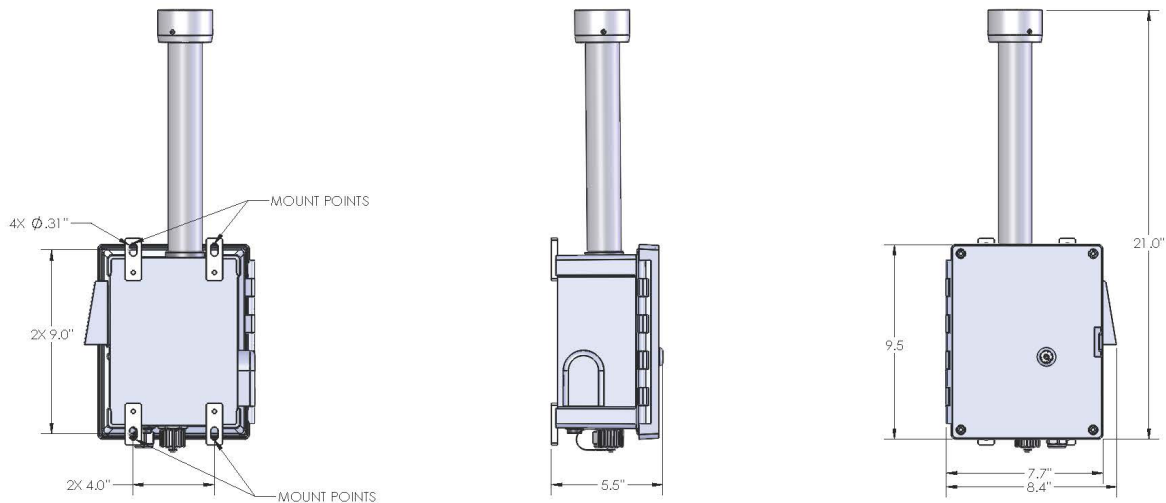

## Specifications

<b>Model</b>	<b>11000</b>
Size Range	0.3 to 25.0 $\mu\text{m}$
Size Channels	Factory calibrated at 0.3, 0.5, 1.0, 2.5, 5.0, 10.0 $\mu\text{m}$
Flow rates / Accuracy	1.2 LPM $\pm 3\%$
Concentration Limits	27,000,000 particles/ft <sup>3</sup> @ 10% coincidence (per ISO 21501-4), 50,000,000 particles/ft <sup>3</sup> @ 10% coincidence (as tested and validated <sup>1</sup> )
Aerosol Concentration Range	0.01 to 20,000 $\mu\text{g}/\text{m}^3$
Light Source	Long life laser diode
Resolution	0.00003 $\mu\text{g}/\text{m}^3$
Zero Stability	No appreciable drift
Count Modes	Cumulative/differential count/m <sup>3</sup> , count/ft <sup>3</sup> , and mass concentration (PM)
Log Interval	Minimum 1 second with no hold time, maximum 99 hours
Calibration	NIST traceable
Vacuum Source	Internal pump with automatic flow control
Number of Channels	Up to 30 channels
Custom Size Channels	Calibration for custom size channels available
Communication Modes	ModBus over RS485 or USB direct (USB to IMS-9K software utility)
Optional Communication Modes	Wi-Fi, LoRaWAN and Ethernet
Environmental Sensor	Temperature and relative humidity probe: -4° to 122°F (-20° to 50°C) $\pm 1^\circ\text{F}$ (0.5°C), 0 -100% $\pm 2\%$ RH
Alarm	Alarms for all particle values, environmental sensors, flow and sensor failure
Calibration	Particle sensor recommended once per year
User Calibration	Field Calibration of Temperature and Humidity possible with included utility software
External Surface	ULTRAGUARD® Fiberglass reinforced polyester - compression molded SMC box and Cover
Enclosure	Temperature controlled ventilation blower and heated backplate for environmental extremes
Dimensions (L x W x H)	5.5" x 8.4" x 21" (13.9 cm x 21.3 cm x 53.3 cm) includes barb fittings
Weight	6.7 lbs. (3.0 kg)
Accessories	Quick start guide, operating manual on USB flash drive, mounting feet
Optional Accessories	Printed manual, data cable, pole mounting hardware kit
Data Storage	Internal 65,000 sample records (rotating buffer) including particle count data and environmental data
Sample Time	1 second to 99 hours
Power	110 to 240 VAC 50/60 Hz universal in-line power supply
Operating Conditions	-4° to 122°F (-20° to 50°C) / 20% to 95% non-condensing
Warranty	2 year Limited Warranty (Extended and Lifetime warranties available)

Airy Technology, Inc. reserves the right to change specifications without notice.  
Contact [www.airytechnology.com](http://www.airytechnology.com) or your local distributor for more details.  
Airy Technology and the Airy Technology logo are trademarks of Airy Technology, Inc. ©2025 Airy Technology, Inc. All rights reserved.

REV 20260407-11000



1490 Central Street  
Stoughton, MA 02072 U.S.A.  
+1-781-341-6898  
[www.airytechnology.com](http://www.airytechnology.com)