

R9301P and R9501P IoT Remote Particle CounterS

0.1 CFM (2.83 LPM)

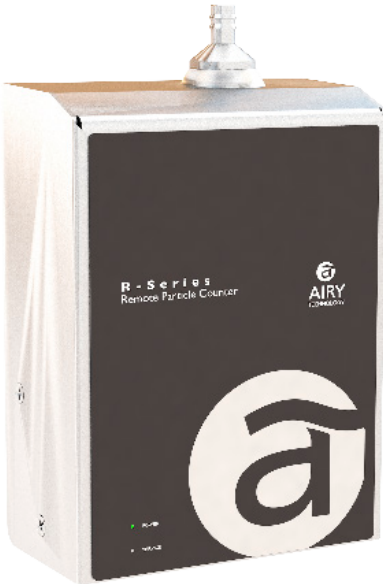

The R9301P and R9501P IoT particle counters provide a range of particle size measurement from 0.3 to 25.0 μm at a flow rate of 0.1 CFM (2.83 LPM). These sensors allow for efficient particle counting with specifications that exceed the ISO 21501-4 and JIS B9921 calibration standards.

These sensors have 6 user-selectable particle size channels (up to 30 channels optional) and are equipped with an internal pump and manifold and do not require an external vacuum source. Integration into a building automation or facility monitoring system is easy via isolated RS-485 Modbus communication, TCP/IP over RJ45, Power over Ethernet, or WiFi (802.11 b/g).

R9301P and R9501P: Features and Benefits

- R9301P: Measures 0.3 μm to 25 μm
- R9501P: Measures 0.5 μm to 25 μm
- 0.1 CFM (2.83 LPM) flow rate
- Long life laser diode technology
- Measures up to 30 channels of simultaneous data
- Accurate in high particle concentration environments
- Internal vacuum pump
- Internal HEPA filter
- User-selectable channel sizes
- Stores up to 65,000 sample records for on-board data redundancy
- (Optional) temperature and relative humidity probe available
- Connect via Modbus RTU/ASCII over isolated RS-485, TCP/IP, PoE, or WiFi
- Complies with ISO 21501-4 and JIS B9921 standards
- Easy to clean and wipe down with minimal particle traps
- Versatile mounting options
- Alarm light
- LED Indicators
- Seamless integration into a facility monitoring system
- Lightweight stainless steel enclosure
- 2 year limited warranty. Extended warranties available.

Specifications

Model	R9301P	R9501p
Size Range	0.3 µm to 25 µm	0.5 µm to 25 µm
Size Channels	Factory calibrated at 0.3, 0.5, 1.0, 2.5, 5.0, 10.0 µm	Factory calibrated at 0.5, 0.7, 1.0, 2.5, 5.0, 10.0 µm
Number of Channels	Up to 30 channels	Up to 30 channels
Counting Efficiency	50% @ 0.3µm; 100% for particles > 0.45 µm per JIS	50% @ 0.5µm; 100% for particles > 0.75 µm per JIS
Flow Rate	0.1 CFM (2.83 LPM)	
Concentration Limits	10,000,000 particles/ft ³ @ 10% coincidence (per ISO 21501-4), 20,000,000 particles/ft ³ @ 10% coincidence (as tested and validated ¹)	
Light Source	Long life laser diode	
Zero Count	< 1 count / 60 minutes (< 1 particles / 6ft ³). No fault count subtraction.	
Alarms	Channel alarms on Raw counts, concentrations or mass (alarms on environmental sensors optional)	
Calibration	NIST traceable	
Vacuum Source	Internal vacuum pump with Internal HEPA filter	
Filtered Exhaust	Internal HEPA filter	
Airflow	Internally monitored	
Configuration/Download	USB mini-B	
Alarm	Alarm LED ring	
Communication Modes	MODBUS™ RTU or ASCII outputs (over isolated RS-485), TCP/IP, PoE, or WiFi	
Environmental Sensor	(Optional) Temp and RH probe 32° to 122°F (0° to 50°C) ±1°F (0.5°C), 15-90% ±2% relative humidity	
Standards	ISO 21501-4 and JIS B9921	
Instrument Calibration	Recommended minimum once per year	
External Surface	Stainless steel	
Dimensions (L x W x H)	3.59" x 1.83" x 5.01" (9.1 cm x 4.6 cm x 12.7 cm) including probes and connectors	
Weight	1.71 lb. (780 grams)	
Accessories	Operating manual on USB flash drive, isokinetic probe, power supply and cable, IMS-9K Software	
Optional Accessories	Printed manual barb fittings, mounting bracket and sample tubing, IMS-RT monitoring system	
Buffer Memory	65,000 sample records (rotating buffer) including particle count data and environmental data	
Sample Time	1 second to 99 hours	
Power	9 - 24 VDC (< 1.5 watts)	
Operating Conditions	41° to 104°F (5° to 40°C) / 20% to 95% non-condensing	
Storage Conditions	32° to 122°F (0° to 50°C) / Up to 98% non-condensing	
Warranty	2 year limited warranty. Extended warranties available.	

1- Validated by independent analysis see paper available at www.particlesplus.com/aac2022_paper

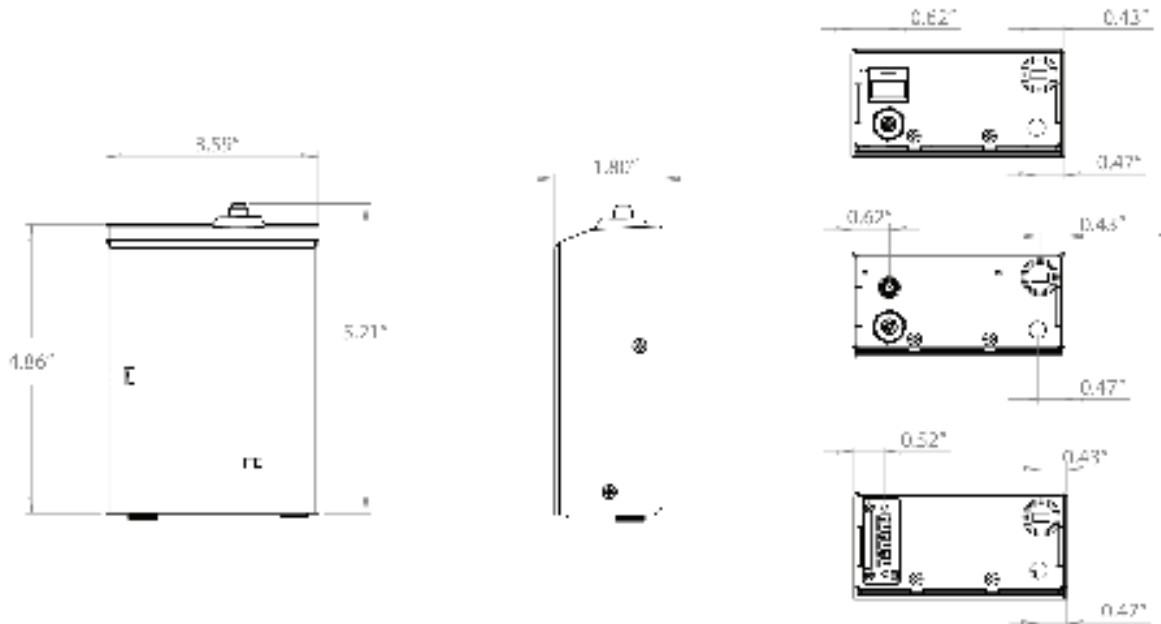

Airy Technology, Inc. reserves the right to change specifications without notice. Contact www.airytechnology.com or your local distributor for more details. Airy Technology and the Airy Technology logo are trademarks of Airy Technology, Inc. ©2024 Airy Technology, Inc. All rights reserved.

REV 20240603-R9301P-R9501P_IOT



31 Tosca Drive
Stoughton, MA 02072 U.S.A.
+1-781-341-6898
www.airytechnology.com