

R9510 IoT Remote Airborne Particle Counter

1.0 CFM (28.3 LPM)

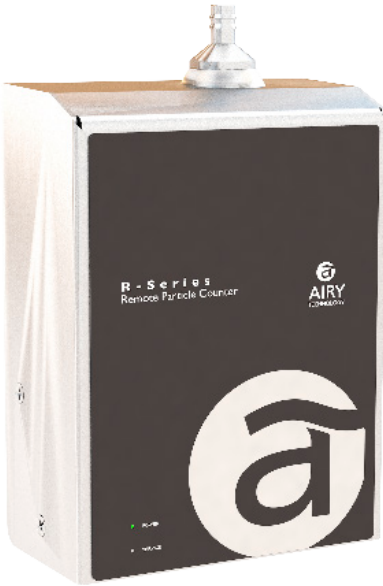

The R9510 particle counters provide a range of particle size measurement from 0.5 to 25.0 μm at a flow rate of 1.0 CFM (28.3 LPM). These sensors allow for efficient particle counting with specifications that exceed the ISO 21501-4 and JIS B9921 calibration standards.

These sensors have 6 user-selectable particle size channels (up to 30 channels optional) and are equipped with an integral critical orifice and flow sensor to provide a stable flow rate from an external vacuum source. Integration into a building automation or facility monitoring system is easy via isolated RS-485 Modbus communication, TCP/IP over RJ45, Power over Ethernet, or WiFi (802.11 b/g).

R9510: Features and Benefits

- Measures 0.5 μm to 25 μm
 - 1.0 CFM (28.3 LPM) flow rate
 - Long life laser diode technology
 - Measures up to 30 channels of simultaneous data
 - Particle concentrations up to 1,500,000 Particles/ft³ @ 10% coincidence loss
 - Internal critical orifice
 - User-selectable channel sizes
 - Stores up to 65,000 sample records for on-board data redundancy
 - (Optional) temperature and relative humidity probe available
 - Connect over Modbus TCP/IP, PoE, or WiFi
 - Complies with ISO 21501-4 and JIS B9921 standards
 - Easy to clean and wipe down with minimal particle traps
 - Versatile mounting options
 - Alarm light
 - LED Indicators
 - Seamless integration into a facility monitoring system
 - Lightweight stainless steel enclosure
 - 2 year limited warranty. Extended warranties available.
-

Specifications

Model	R9510-TCP, R9510-PoE, and R9510-WiFi
Size Range	0.5 µm to 25 µm
Size Channels	Factory calibrated at 0.5, 1.0, 2.5, 5.0, 10.0 µm
Number of Channels	6 channels (up to 30 optional)
Counting Efficiency	50% @ 0.5µm; 100% for particles > 0.75 µm per JIS
Flow Rate	1.0 CFM (28.3 LPM)
Concentration Limits	1,500,000 particles/ft ³ @ 10% coincidence (per ISO 21501-4), 3,000,000 particles/ft ³ @ 10% coincidence (as tested and validated ¹)
Light Source	Long life laser diode
Zero Count	< 1 count / 5 minutes (< 1 particles / 15ft ³). No fault count subtraction.
Alarms	Channel alarms on Raw counts, concentrations or mass (alarms on environmental sensors optional)
Calibration	NIST traceable
Vacuum Requirements	External vacuum > 15" (38.1cm) of Hg
Airflow	Internally monitored
Configuration/Download	USB mini-B
Alarm	Alarm LED ring
Communication Modes	MODBUS™ TCP/IP, PoE, or WiFi
Standards	ISO 21501-4 and JIS B9921
Instrument Calibration	Recommended minimum once per year
External Surface	Stainless steel
Dimensions (L x W x H)	3.59" x 1.83" x 5.01" (9.1 cm x 4.6 cm x 12.7 cm) including probes and connectors
Weight	1.08 lb. (494 grams)
Accessories	Wiring Connector, operating manual on USB flash drive
Optional Accessories	Power Supply, Remote Mounting Bracket, Stainless Steel Barbed Isoprobe (1.0 CFM/28.3 LPM), Filter Assembly, and Sample & Vacuum Tubing
Buffer Memory	65,000 sample records (rotating buffer) including particle count data and environmental data
Sample Time	1 second to 99 hours
Power	9 - 24 VDC (< 1.5 watts)
Operating Conditions	41° to 104°F (5° to 40°C) / 20% to 95% non-condensing
Storage Conditions	32° to 122°F (0° to 50°C) / Up to 98% non-condensing
Warranty	2 year limited warranty. Extended warranties available.

1- Validated by independent analysis see paper available at www.particlesplus.com/aac2022_paper

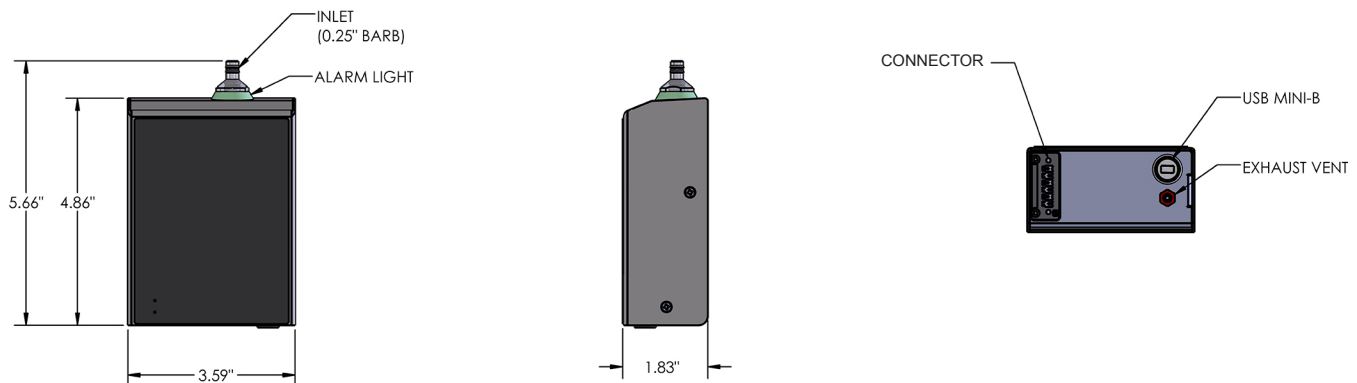

Airy Technology, Inc. reserves the right to change specifications without notice. Contact www.airytechnology.com or your local distributor for more details. Airy Technology and the Airy Technology logo are trademarks of Airy Technology, Inc. ©2024 Airy Technology, Inc. All rights reserved.

REV 20240603-R9510_IOT



31 Tosca Drive
Stoughton, MA 02072 U.S.A.
+1-781-341-6898
www.airytechnology.com